

ultrasonic spot welding systems

ACTUATORS

FEATURES

- Pneumatic Actuation
- Patented 90° Self-Orienting Keyed Horns and Tips
- Single Piece, Dual Nodal Mount Horn and Booster Stack
- Precision Micrometer Stack Up and Down Stops
- Independent Horn and Converter Air Cooling Flow Control
- Pre-Lubricated and Sealed Linear Bearings



MWB40 Actuator
on Integral Base



MWP40 Actuator
on Plate



MWA40
Actuator

Sonics' 40 kHz ultrasonic metal welding systems consist of an actuator (available as a stand-alone unit or on a plate or a base, as shown above) and a power supply, the MX or MSC series, as shown below.

POWER SUPPLIES

MODELS

MXC Remote Impulse Actuation

MXT Time Based Weld Mode

MXE Time and Energy Based Weld Modes

MSC *SmartControl* with Time, Energy and Height-Based Weld Modes



MX Series Power Supplies



MSC *SmartControl*
Power Supplies

Sonics' 40 kHz power supplies come in 2 versions, the MX Series, with standard keypad operation and the *SmartControl* (MSC) Series with full color touch screen controls. The features of the models are compared below.

POWER LEVELS

- 400 Watts Peak Power
- 800 Watts Peak Power

POWER SUPPLY FEATURES	MXC	MXT/ MXE	MSC
Microprocessor Controlled	■	■	■
Automatic Frequency Tuning	■	■	■
Digital Amplitude Control	■	■	■
Digital Force Triggering		■	■
Weld Time Delay Setting		■	■
Afterburst Time Setting		■	■
Multiple Job Storage		■	■
Digital Stack Wattage Display	■	■	■
Digital Stack Frequency Display	■	■	■
Weld Cycle Counter	■	■	■
Upper and Lower Weld Mode Limit Settings		■	■
Soft Start Overload Protection Circuitry	■	■	■
Load Regulation Circuitry	■	■	■

POWER SUPPLY FEATURES	MXC	MXT/ MXE	MSC
Color Touch Panel Operator Screen			■
Weld Cycle Graph Chart Screen			■
Weld Teach Mode			■
Weld Sequence Mode			■
Amplitude and Pressure Ramping			■
Timed Converter and Horn Air Cooling Cycle			■
English and Metric Weld-to-Height Settings			■
Password Protected Four-Level User Access			■
Serial Printer Port Connection		■	
PLC I/O Interface Connection	■	■	■
PC Interface Connection			■
Bar Code Scanner Connection			■

system options

EKIT:

SmartControl
Electronic
Pressure
and Height
Control



**Foot Pedal
Switch with
Emergency Stop**



**X-Y Adjustable
Fixture Anvil**

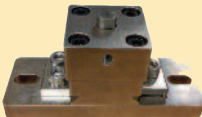

**SmartControl
Bar Code
Scanner**



Secondary Booster:
Aluminum or
Titanium
Secondary
Booster



Smart Program:
SmartControl
System PC
Interface
Program



MWB40 dimensional data

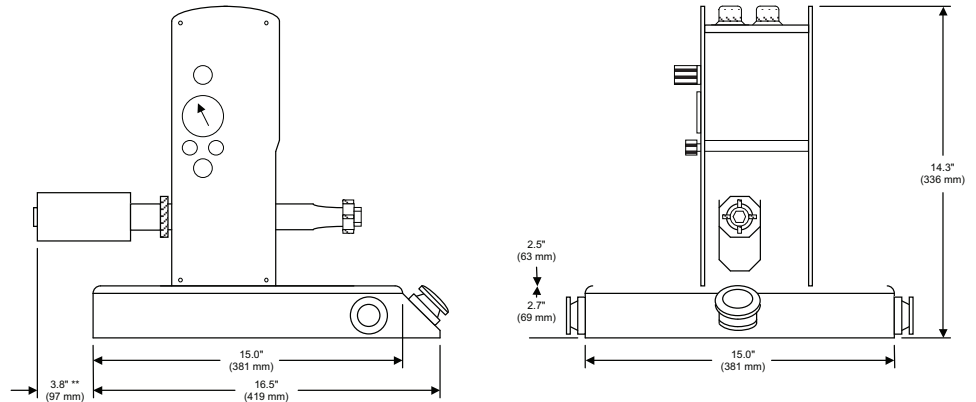

* Add Approximately 2.5" (63 mm) for Secondary Booster

specifications

Actuator Data:

MWA40 Actuator Weight: 28 Lbs. (12.7 kg)
MWP40 Actuator on Plate Weight: 40 Lbs. (18.1 kg)
MWB40 Actuator on Integral Base Weight: 69 Lbs. (31.2 kg)
Pneumatic Requirement: 80 PSI Clean and Dry Air Service

Low Profile Power Supply Data:

Peak Output Power: 400 Watts (0.4 kW) or 800 Watts (0.8 kW)
Power Supply Weight: 21 Lbs. (9.5 kg)
Power Supply Dimensions: 15.2" (386 mm) Wide x 7.0" (178 mm) High x 18.7" (476 mm) Deep
Power Requirement: 220 VAC Single Phase